

VIEW FROM STARTER END

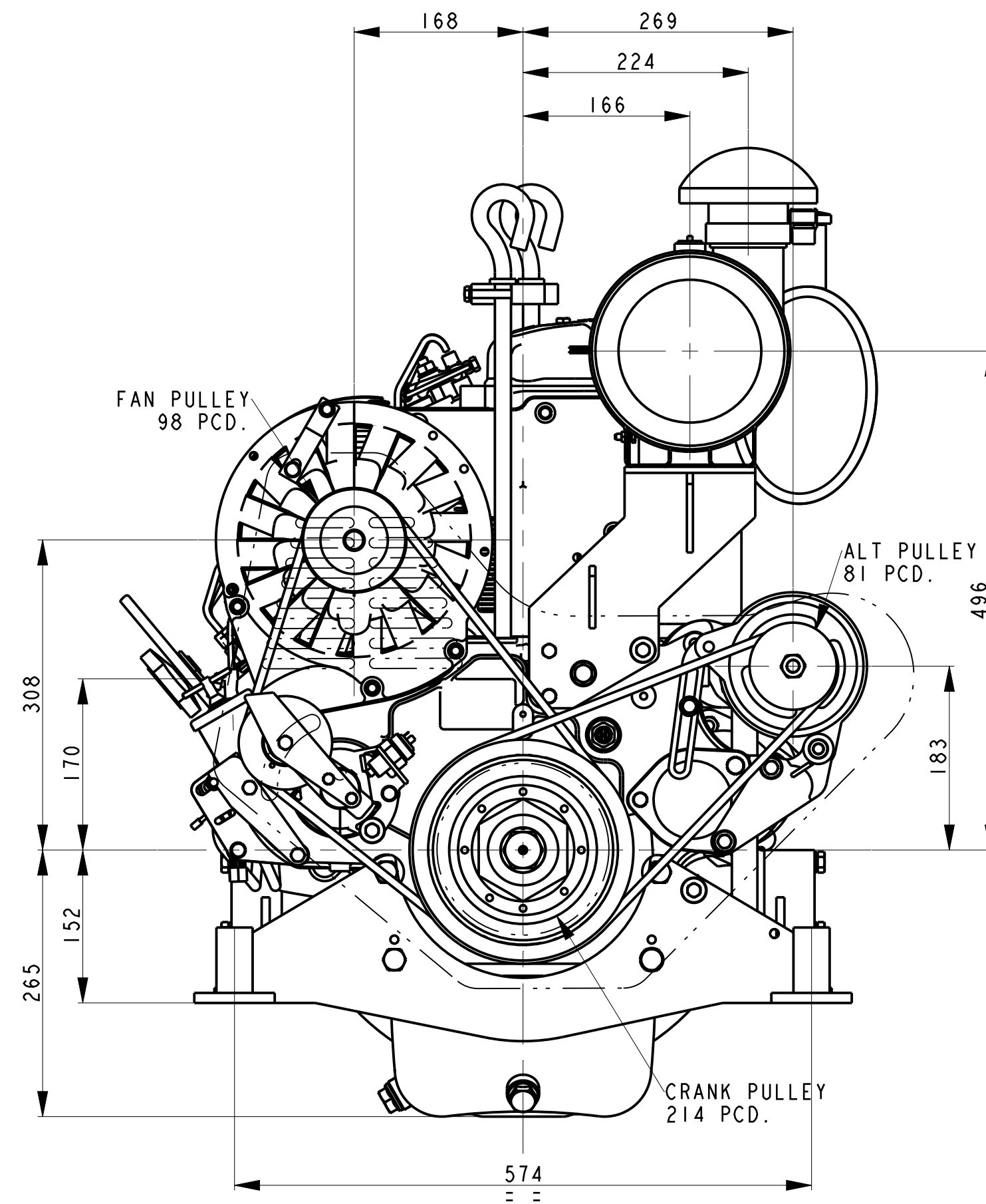

VIEW FROM GEAR END

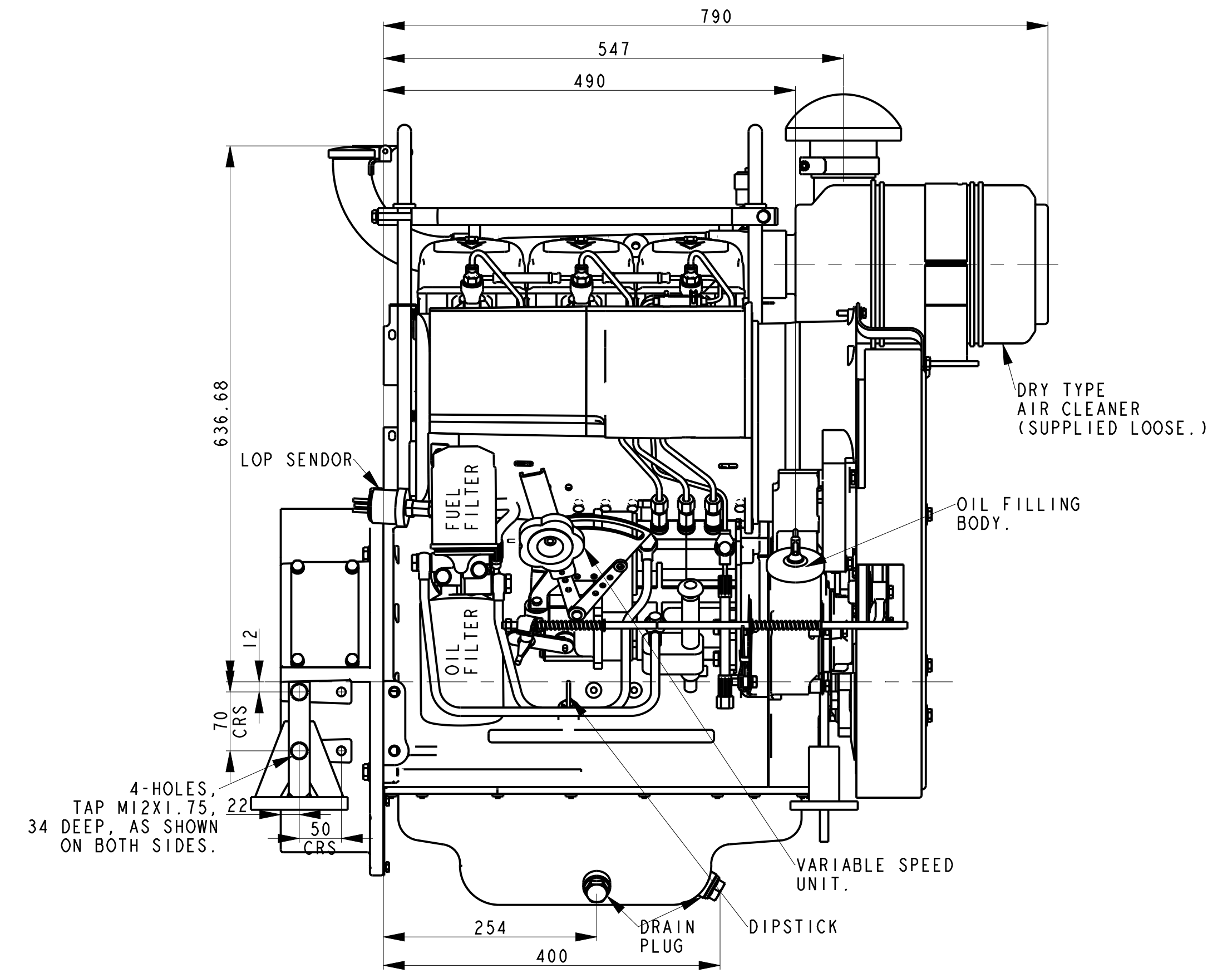

VIEW FROM FLYWHEEL END

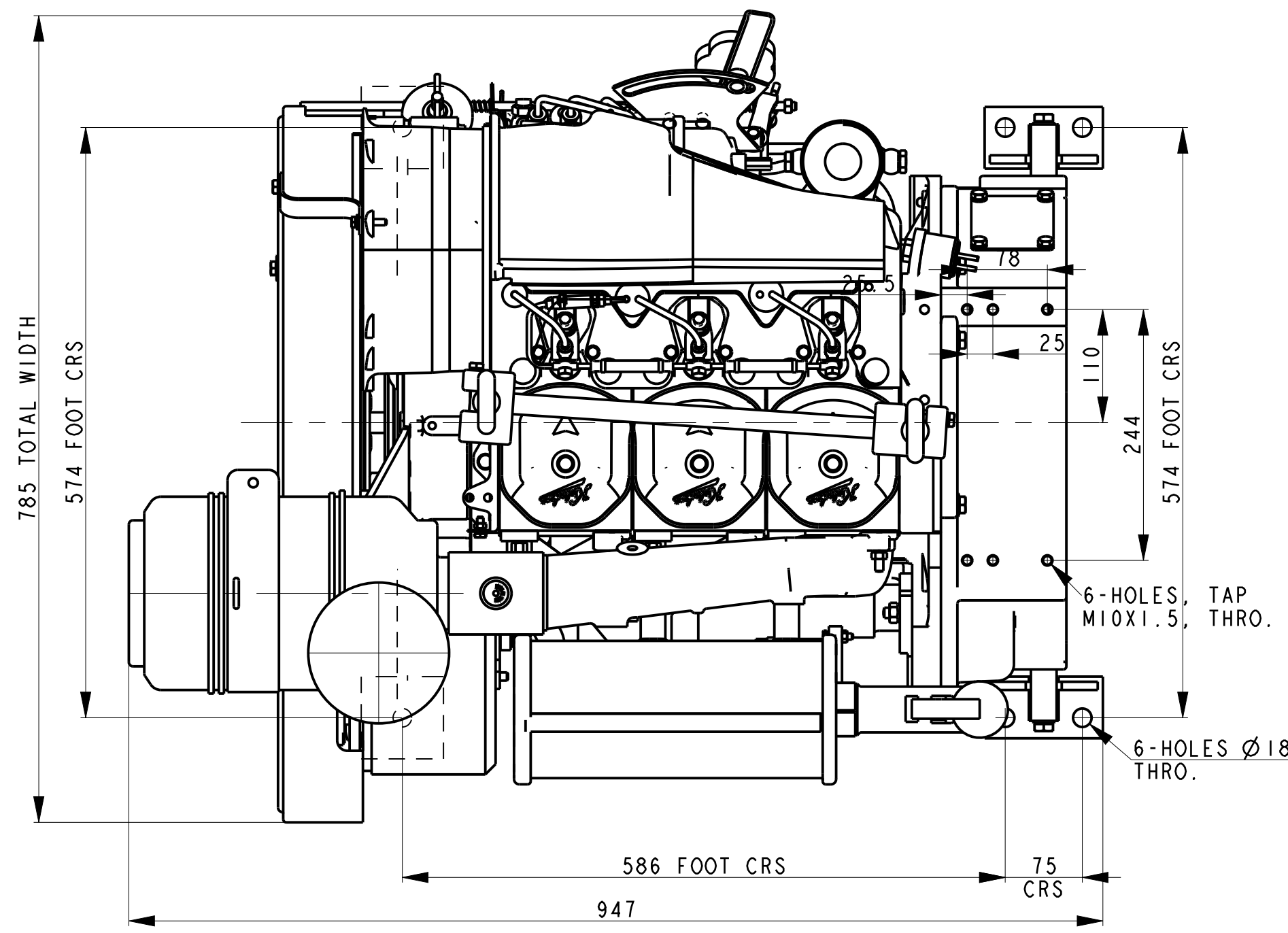

VIEW FROM TOP END

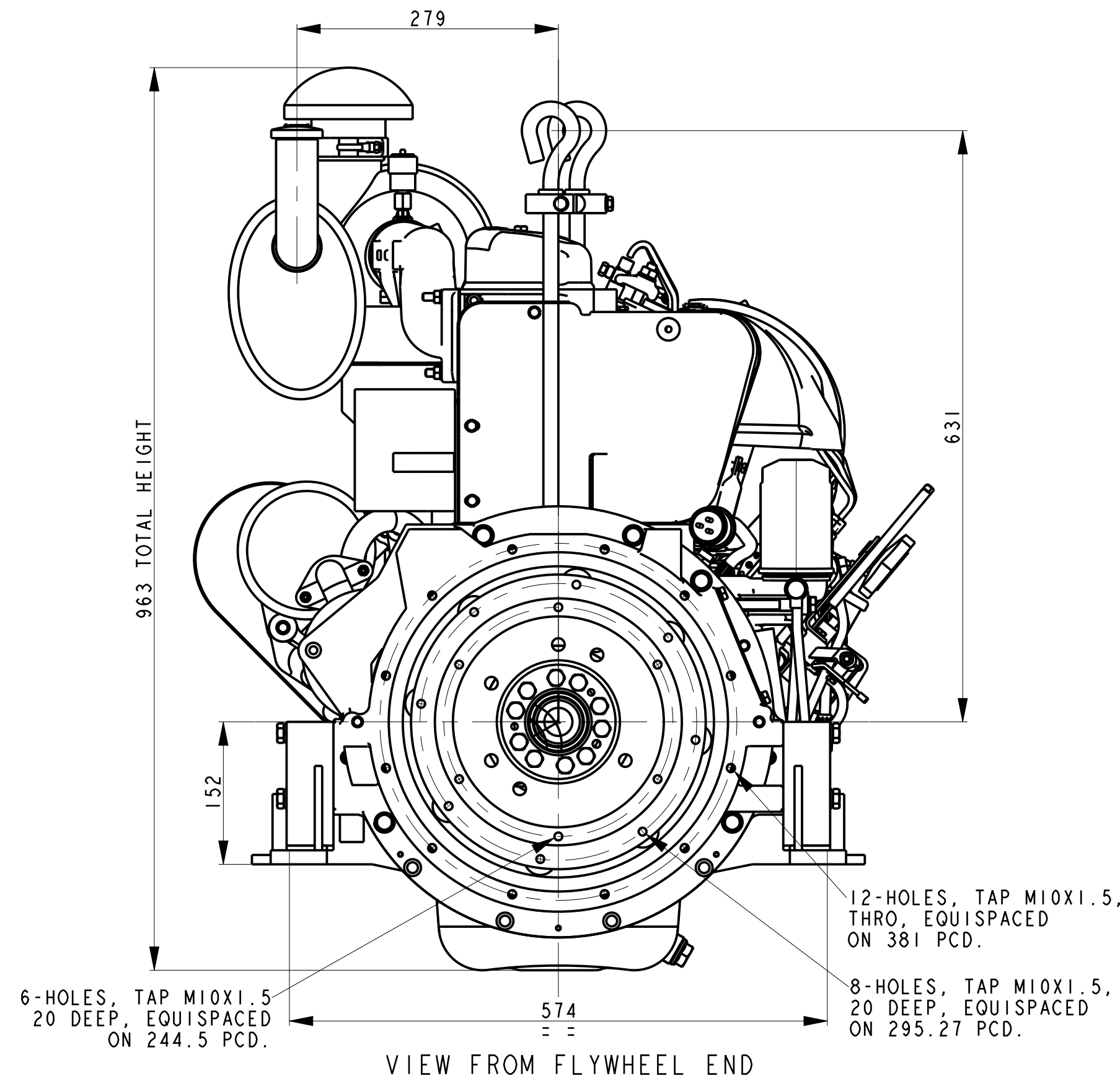

VIEW FROM FLYWHEEL END

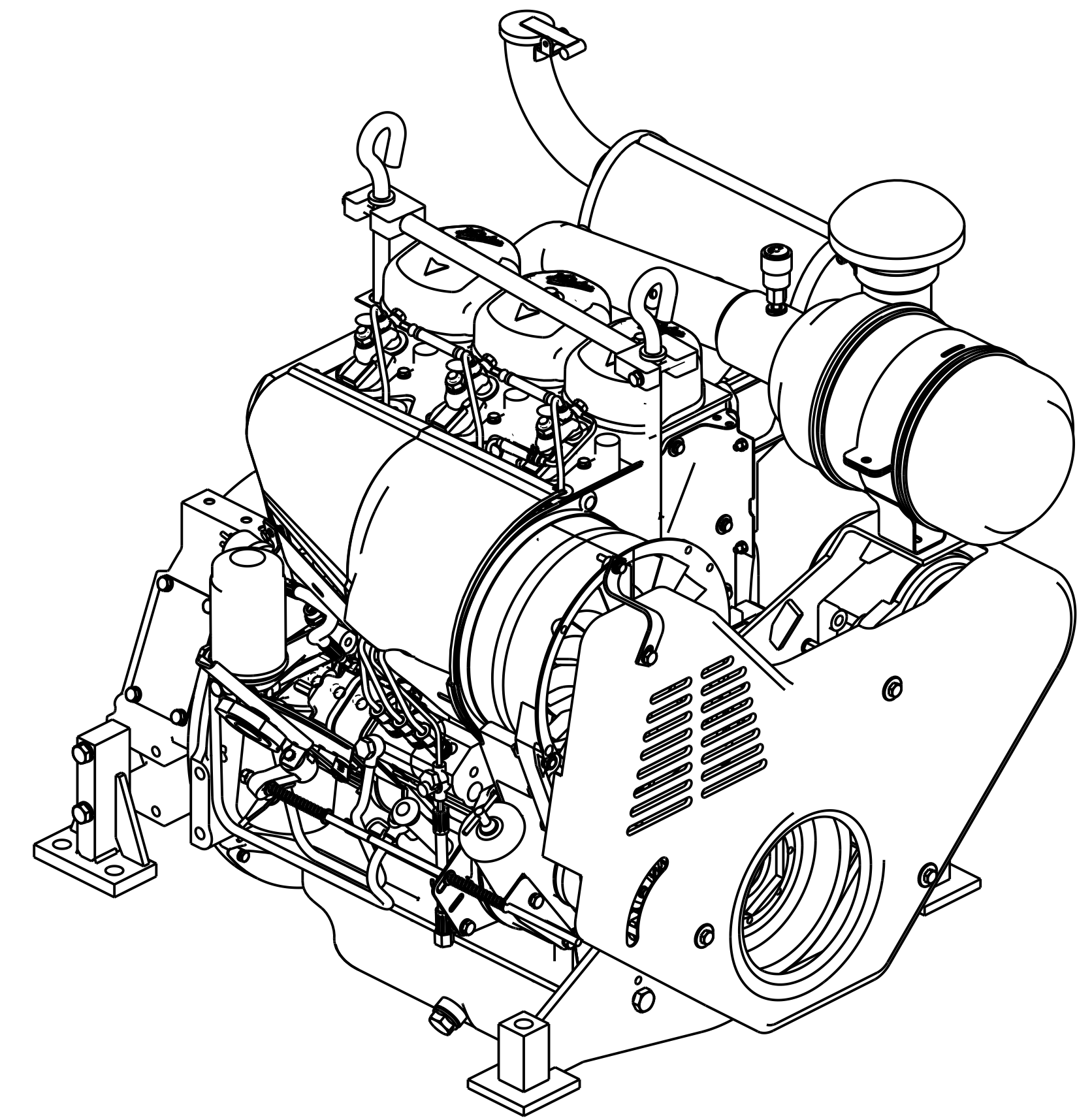

IF IN DOUBT ASK  
PRINTS OF PREVIOUS REVISION NO. SHOULD BE SCRAPPED

THIS DRAWING IS PROPERTY OF KIRLOSKAR OIL ENGINES LTD. AND MUST BE RETURNED ON REQUEST. IT IS SUBMITTED AS CONFIDENTIAL INFORMATION WITH OUR ENQUIRY, TENDER, ORDER OR CONTRACT NO. IT IS NOT TO BE ISSUED FOR ANY OTHER PURPOSE OR ORDER NOR MAY BE COPIED OR LENT WITHOUT OUR AUTHORITY IN WRITING.  
FORMAT No. RBE/FORM/056/01 (REFER DOP No. RBE 4.4/03)

LIFECYCLE STATE:- RELEASED				CASTING/FORGING DRG. NO. ---			
UNLESS OTHERWISE SPECIFIED				CAD DRG. FILE:- PLM			
● ALL DIMENSIONS ARE IN mm.				MATERIAL :- ---			
● SURFACE ROUGHNESS AS PER CO. STD. NO. 10501.				HEAT TREATMENT :- ---			
● UNMENTIONED TOLERANCES AS PER CO. STD. NO. 11001.				WEIGHT (kg) :- ---			
● REMOVE ALL SHARP BURRS AND SHARP EDGES.				DRN CKJ			
● DRAWING NOT TO BE SCALED.				TITLE ENGINE INSTALLATION			
01 FLYWHEEL HOUSING CHANGED FROM SAE 3 TO SAE 4. LOP SENSOR ADDED.				DATE 16/04/2015			
00 NEW RELEASE				DRAWING NO. 03.1242.00.00			
No. REVISION ZONE MODIFIED BY REF. No. DATE				KIRLOSKAR OIL ENGINES LTD., PUNE 411 003 (INDIA)			
				REV. NO. 01			