

VIEW FROM STARTER END

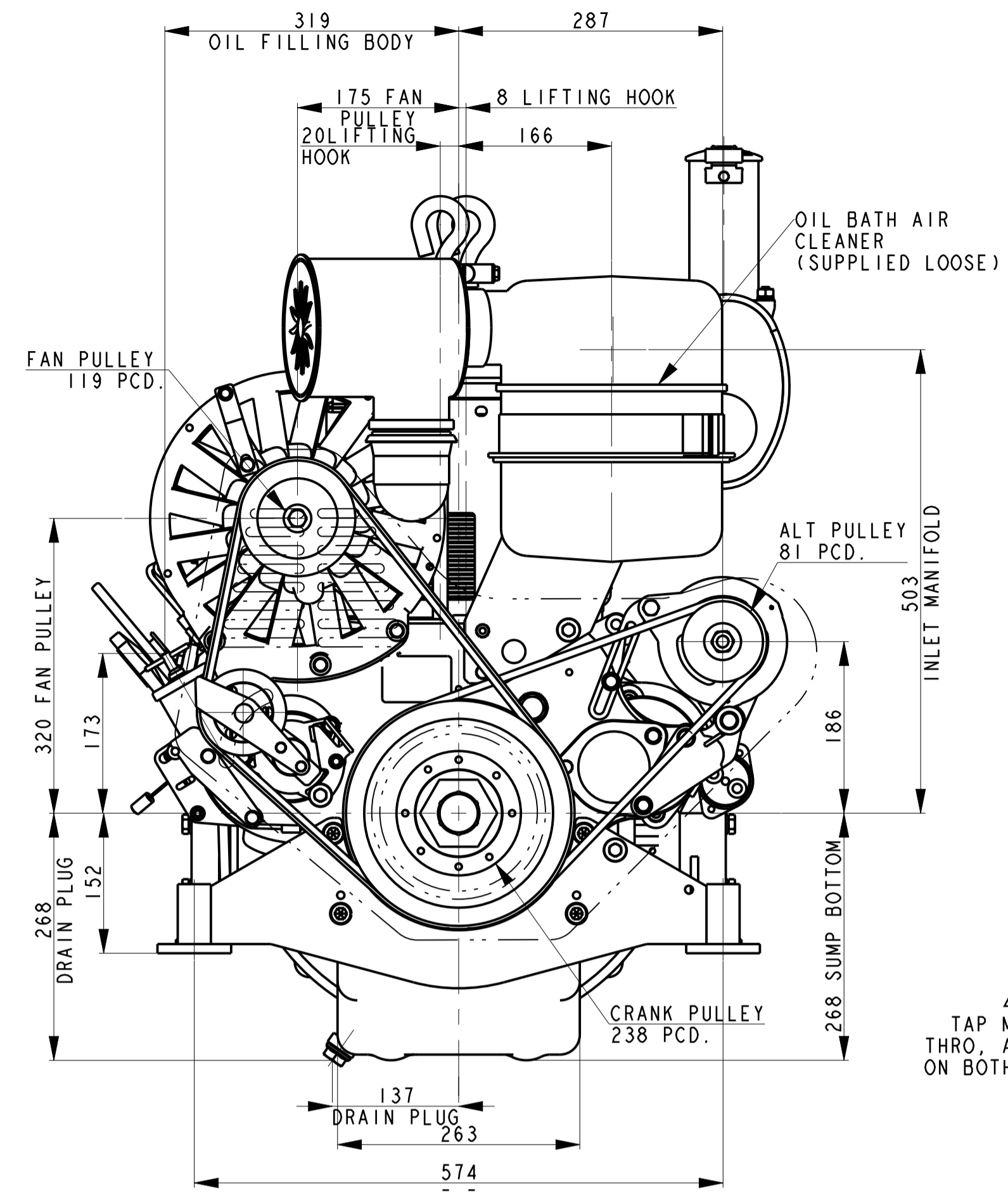

VIEW FROM GEAR END

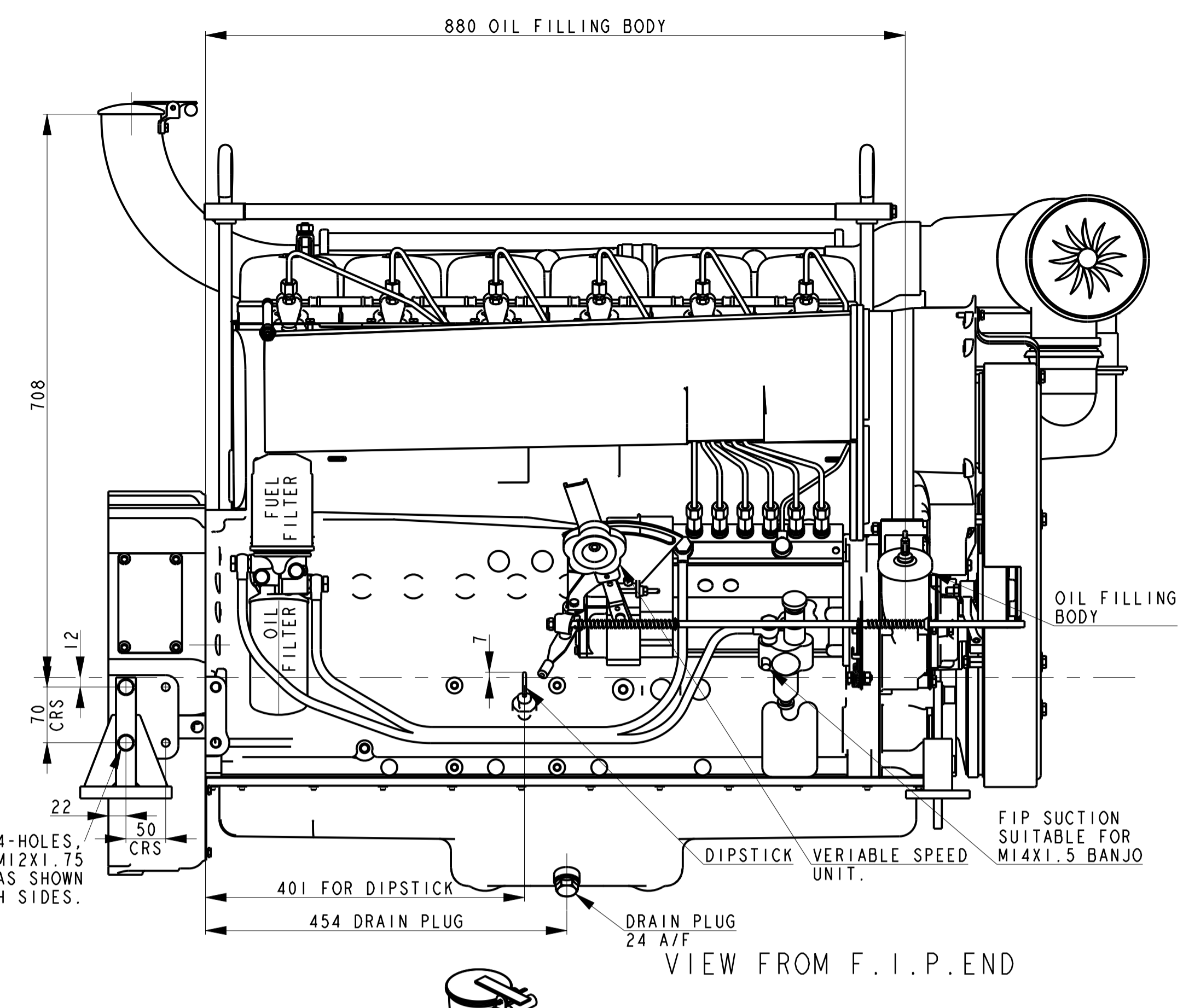

VIEW FROM F.I.P. END

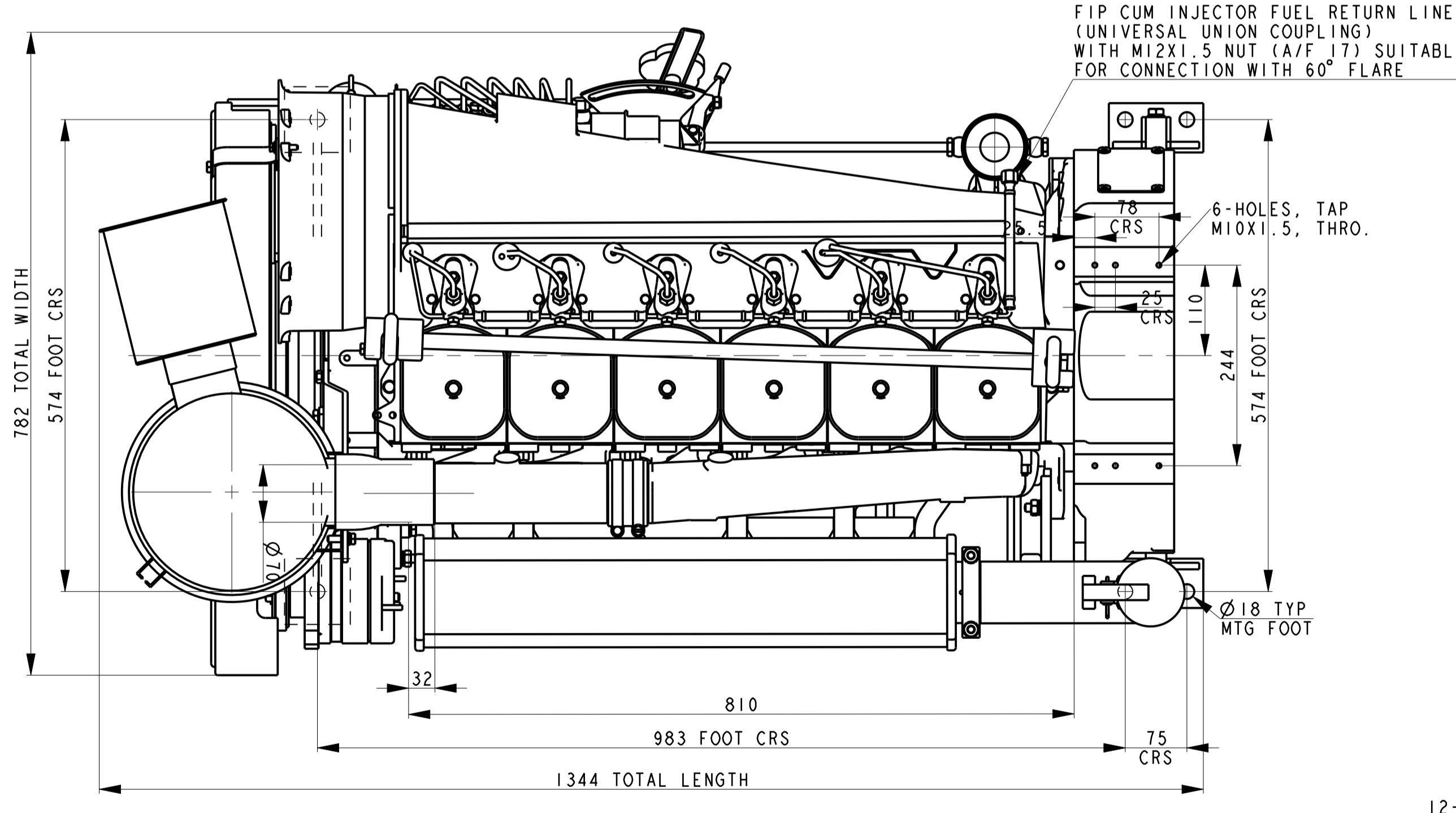

VIEW FROM TOP END

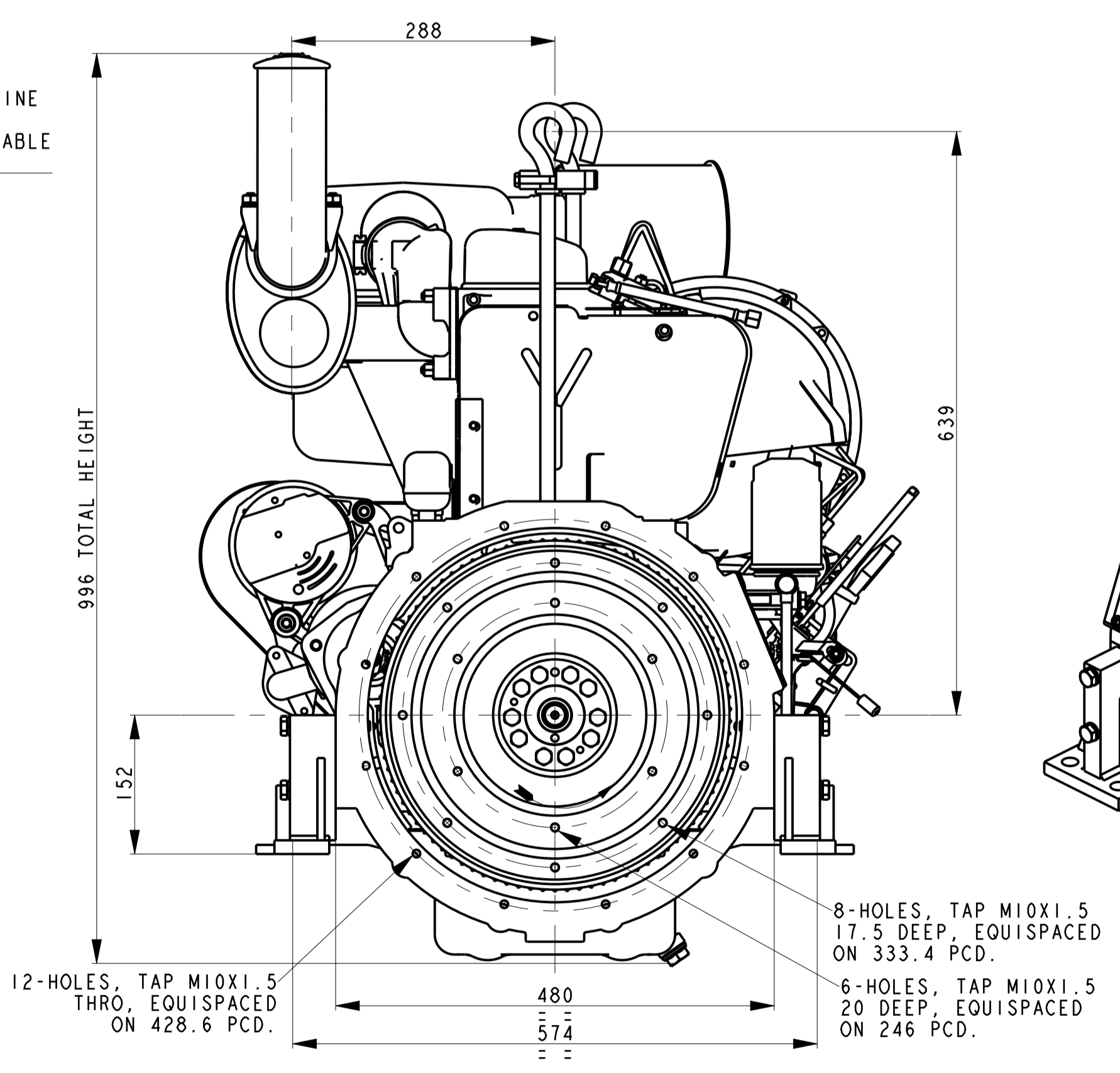

VIEW FROM FLYWHEEL END

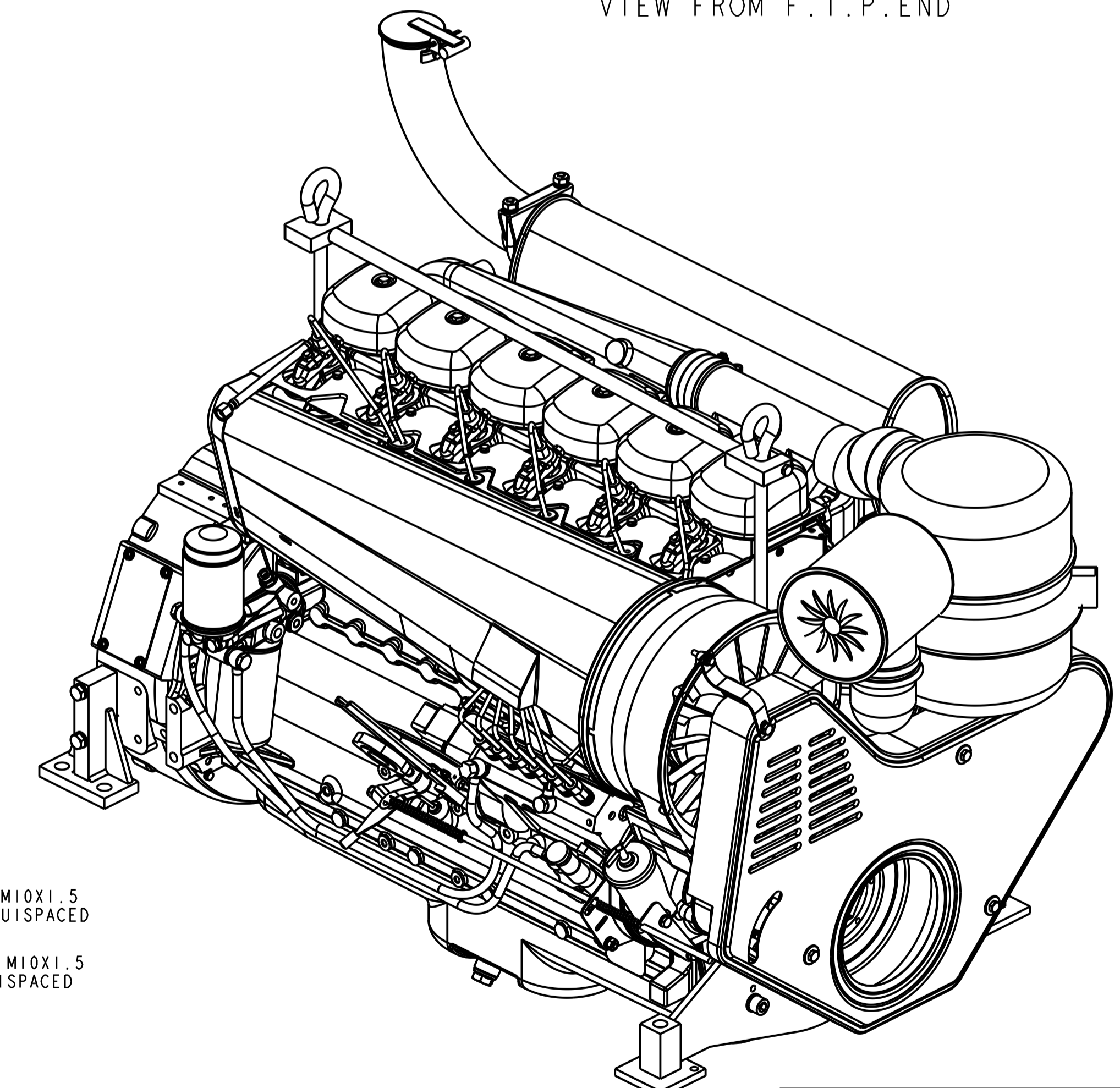

IF IN DOUBT ASK
PRINTS OF PREVIOUS REVISION NO. SHOULD BE SCRAPPED

THIS DRAWING IS PROPERTY OF KIRLOSKAR OIL ENGINES LTD. AND MUST BE RETURNED ON REQUEST. IT IS SUBMITTED AS CONFIDENTIAL INFORMATION WITH OUR ENQUIRY, TENDER, ORDER OR CONTRACT NO. IT IS NOT TO BE ISSUED FOR ANY OTHER PURPOSE OR ORDER NOR MAY BE COPIED OR LENT WITHOUT OUR AUTHORITY IN WRITING.
FORMAT No. RBE/FORM/056/01 (REFER DOP No. RBE 4.4/03)

UNLESS OTHERWISE SPECIFIED				CAD DRG. FILE:- PLM				CASTING/FORGING DRG. NO.	
● ALL DIMENSIONS ARE IN mm.				MATERIAL :-				WEIGHT (kg) :-	
● SURFACE ROUGHNESS AS PER CO. STD. NO. 10501.				HEAT TREATMENT :-				---	
● UNMENTIONED TOLERANCES AS PER CO. STD. NO. 11001.				DRN (CKJ)				TITLE	
● REMOVE ALL SHARP BURRS AND SHARP EDGES.				CHAMFER				ENGINE INSTALLATION	
● DRAWING NOT TO BE SCALED.				APPD.				SCALE	
01 DRY TYPE AIR CLEANER CHANGED TO OIL BATH TYPE SAE 4 FLY HSG CHANGED TO SAE 3				DATE 01/04/2015				19:100	
00 NEW RELEASE				UNMENTIONED				SHT. NO	
No. REVISION				KIRLOSKAR OIL ENGINES LTD.,				DRAWING NO.	
ZONE MODIFIED BY REF. No. DATE				PUNE 411 003 (INDIA)				06.1222.00.00	
No. REVISION				UNDERCUT				REV. NO.	
ZONE MODIFIED BY REF. No. DATE								01	

LIFECYCLE STATE:- RELEASED