

VIEW FROM STARTER END

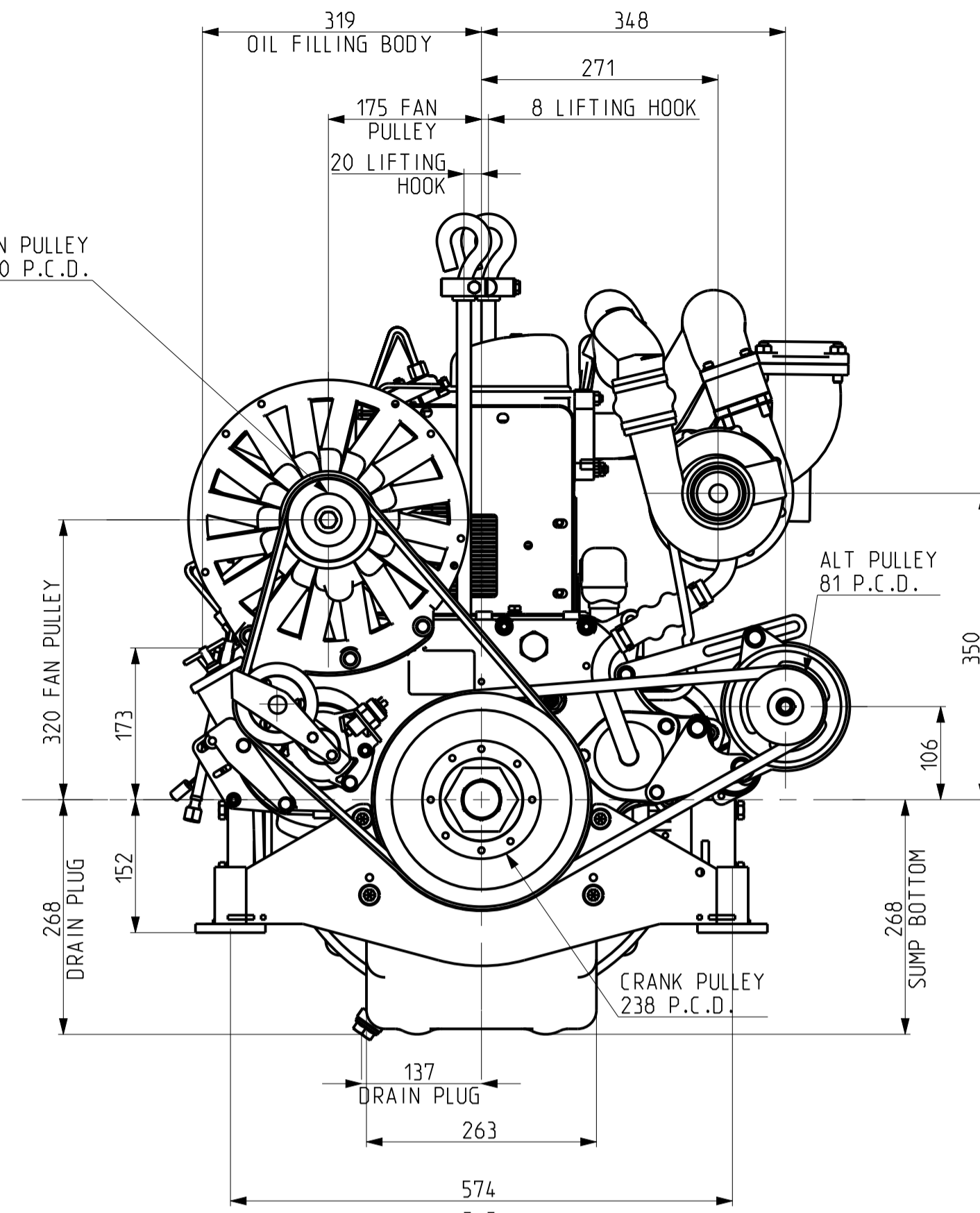

VIEW FROM GEAR END

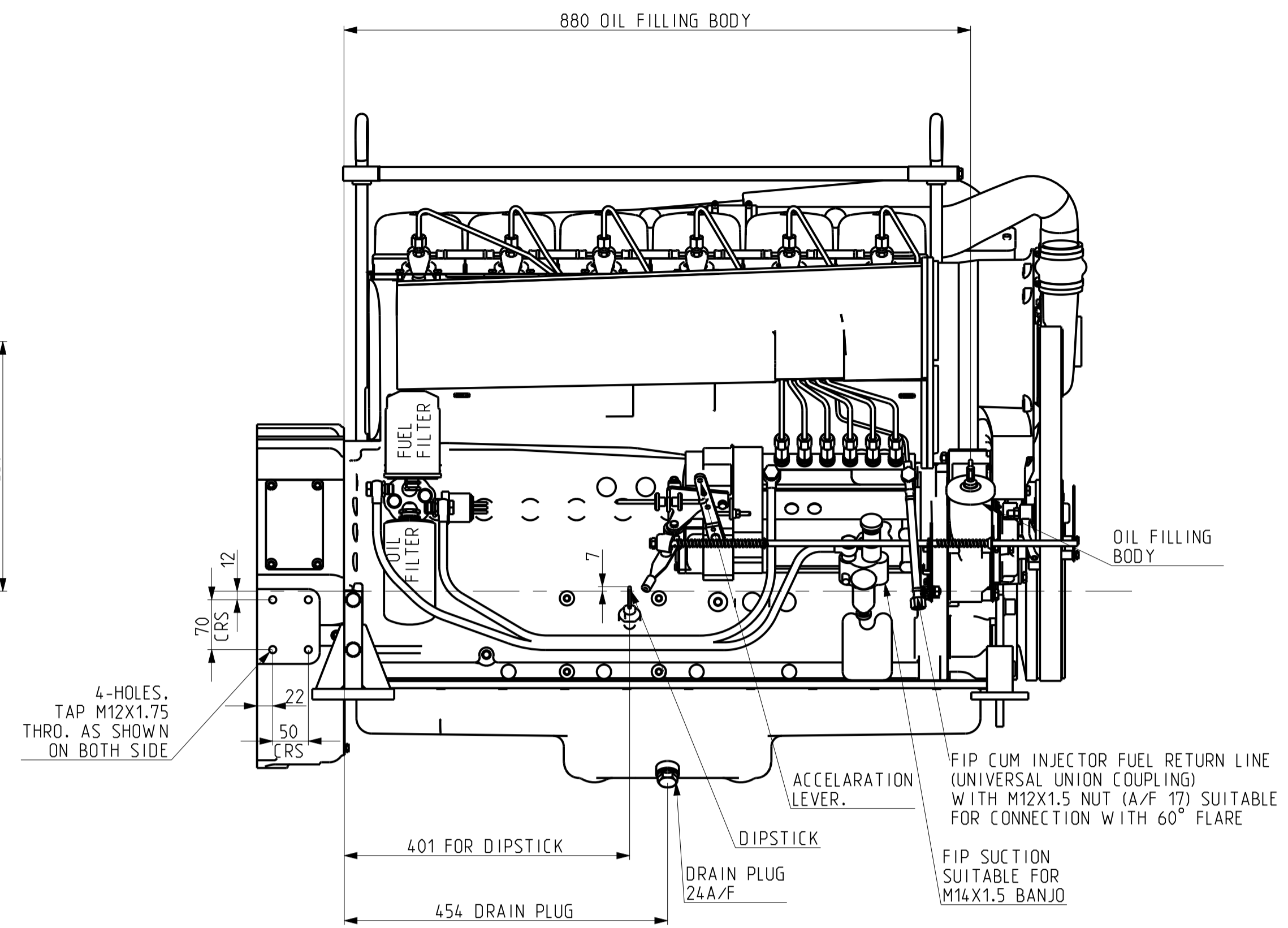

VIEW FROM F.I.P. END

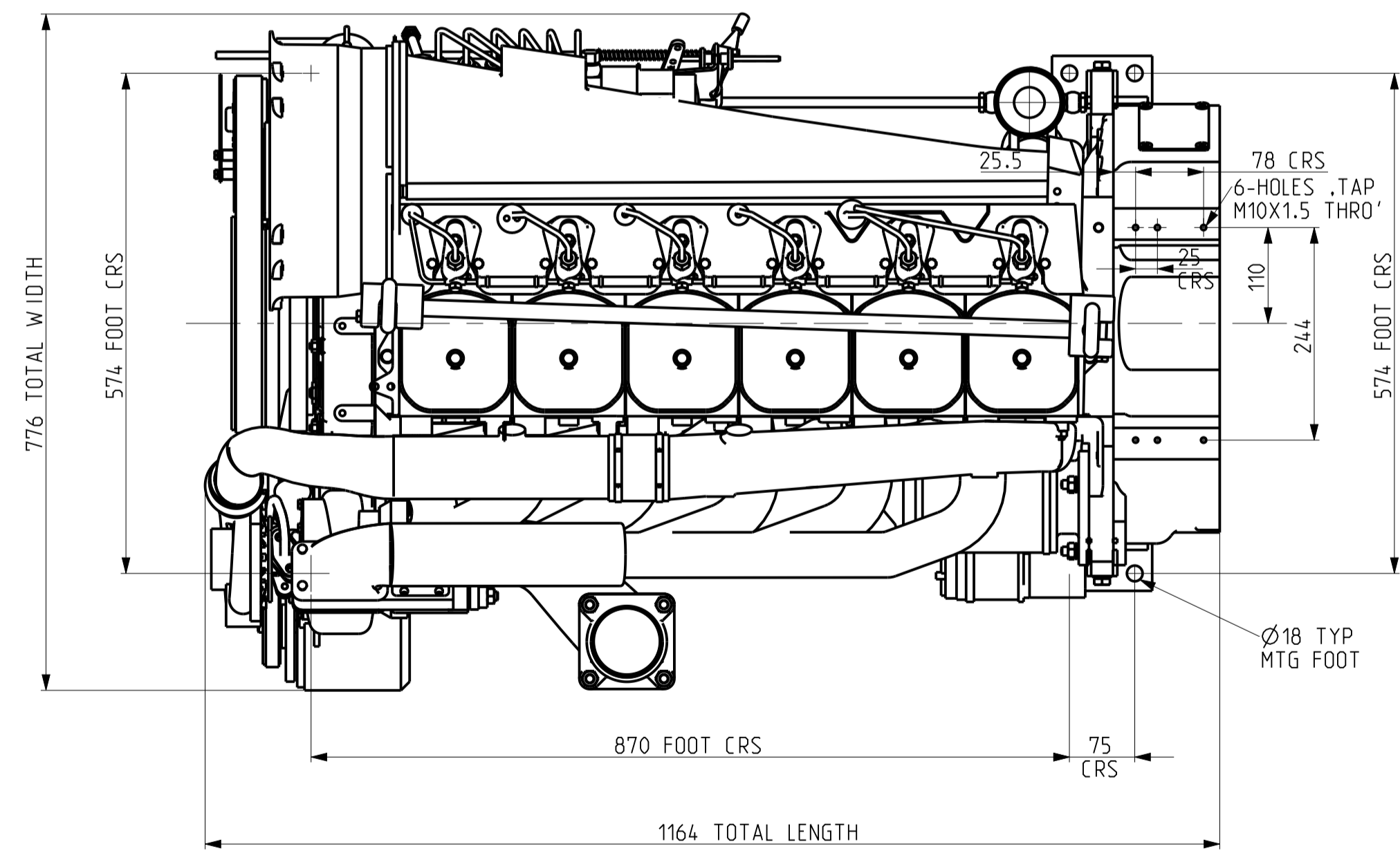

VIEW FROM TOP END

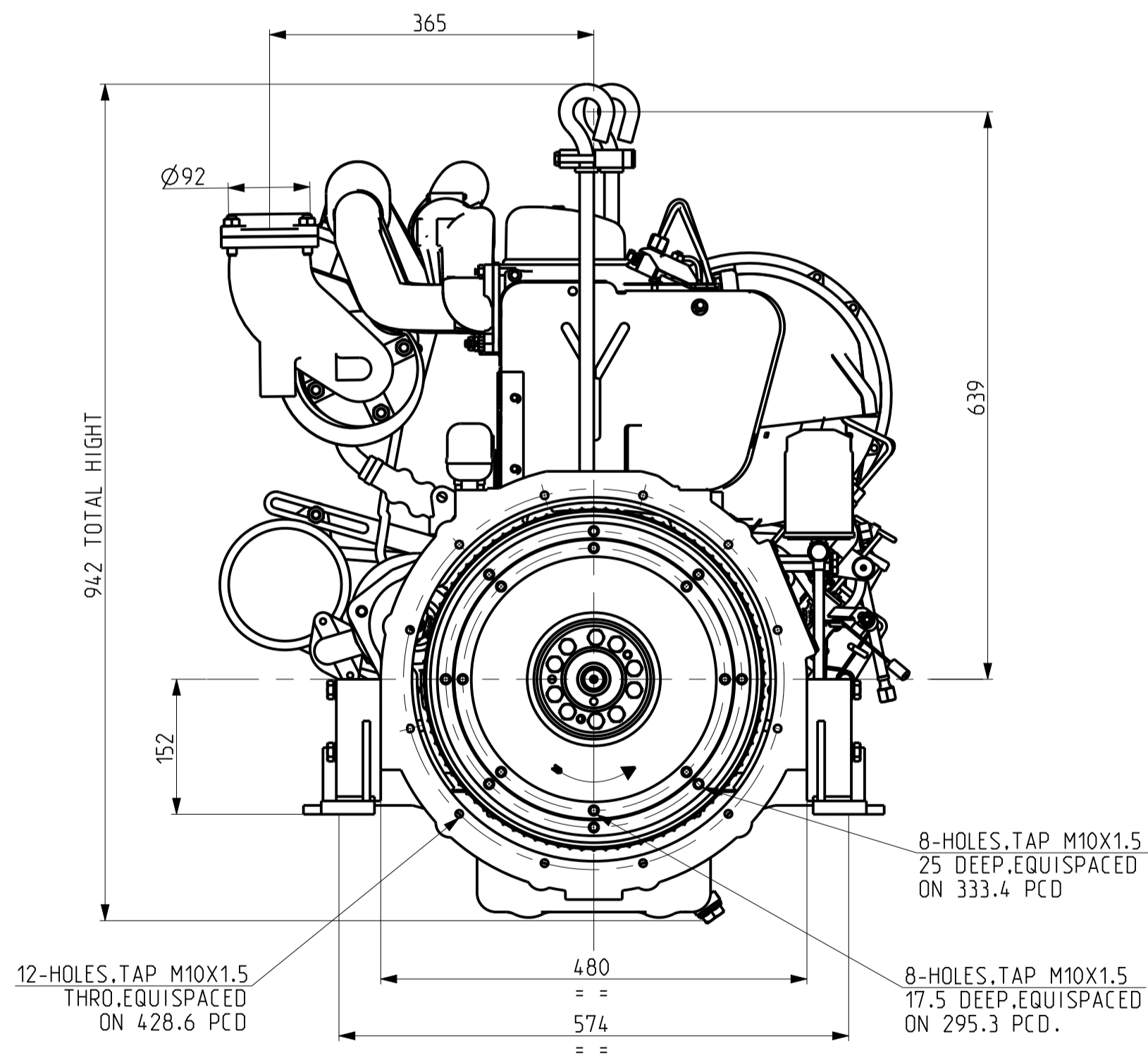

VIEW FROM FLYWHEEL END

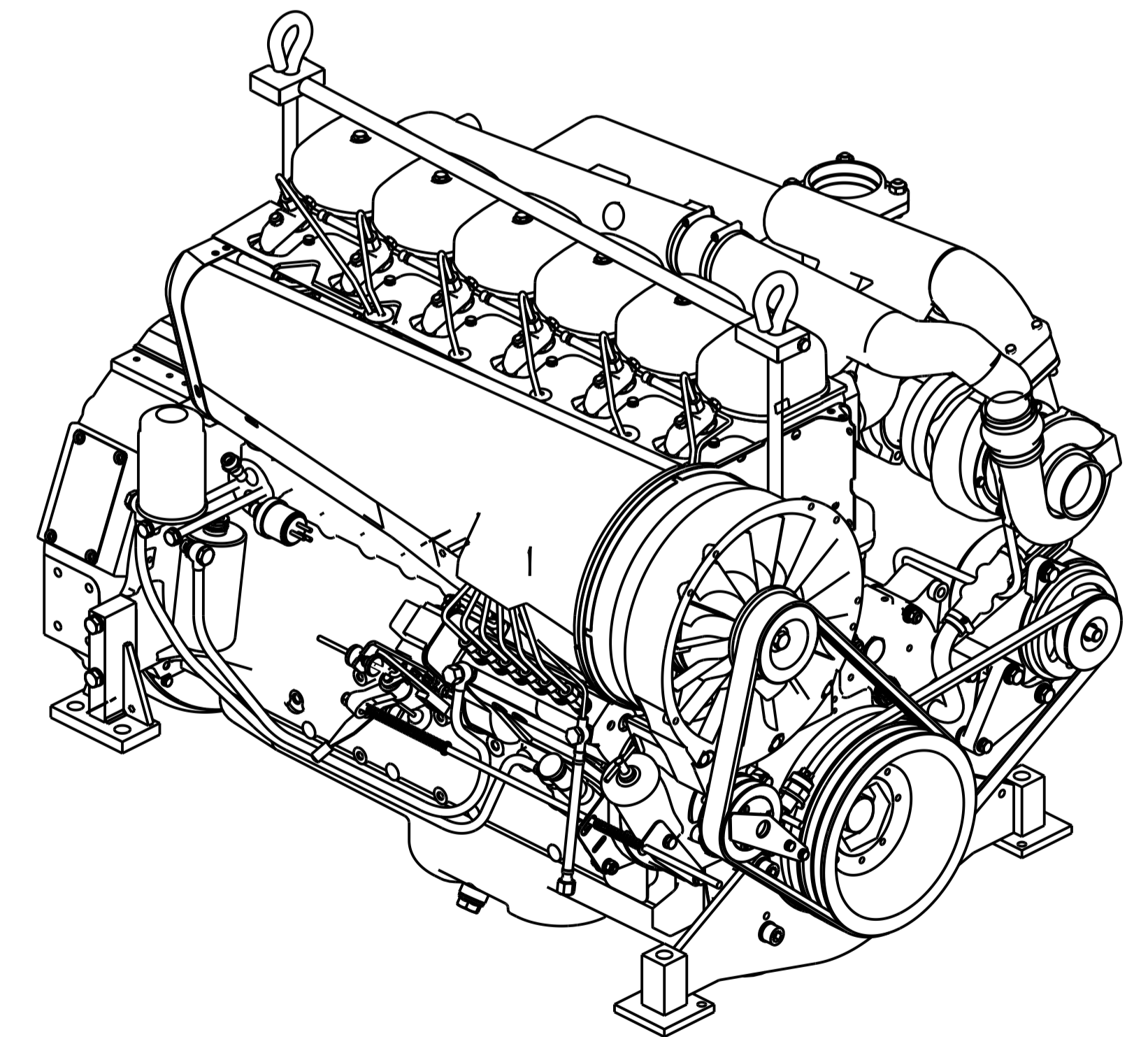

IF IN DOUBT ASK

PRINTS OF PREVIOUS REVISION NO. SHOULD BE SCRAPPED

THIS DRAWING IS PROPERTY OF KIRLOSKAR OIL ENGINES LTD. AND MUST BE RETURNED ON REQUEST. IT IS SUBMITTED AS CONFIDENTIAL INFORMATION WITH OUR ENQUIRY, TENDER, ORDER OR CONTRACT NO. IT IS NOT TO BE ISSUED FOR ANY OTHER PURPOSE OR ORDER NOR MAY BE COPIED OR LENT WITHOUT OUR AUTHORITY IN WRITING.

FORMAT No. RBE/FORM/056/01 (REFER DOP No. RBE 4.4/03)

No.		REVISION	ZONE	MODIFIED BY	REF. No.	DATE	No.	REVISION	ZONE	MODIFIED BY	REF. No.	DATE	UNLESS OTHERWISE SPECIFIED		CAD DRG. FILE:-		PLM		CASTING/FORGING DRG. NO.	
													● ALL DIMENSIONS ARE IN mm.		MATERIAL :-		HEAT TREATMENT :-		WEIGHT (kg) :-	
													● SURFACE ROUGHNESS AS PER CO. STD. NO. 10501.		DRN		TITLE		TYPE	
													● UNMENTIONED TOLERANCES AS PER CO. STD. NO. 11001/M.		CHAMFER		ENGINE INSTALATION		SCALE	
													● REMOVE ALL SHARP BURRS AND SHARP EDGES.		APPD.		S/F PUMP SET APPLICATION		SHT. NO	
													● DRAWING NOT TO BE SCALED.		DATE		DRAWING NO.		REV. NO.	
													UNMENTIONED		25/10/2016		06.1157.00.00		1 OF 1	
													RAD11		KIRLOSKAR OIL ENGINES LTD..		00			
													CHAMFER		PUNE 411 003 (INDIA)					
													UNDERCUT							

LIFECYCLE STATE:- RELEASED

