

## Tier 2

### A 121.6 kW turbo-charged 6-cylinder engine

# 6BG1T

- Environmental performance that meets Tier 2 regulations
- Powerful 121.6 kW output
- Environmentally friendly and economical with low fuel consumption
- Lightweight and compact, with outstanding quiet performance
- Highly rated around the world for reliability and durability

► Suitable for a wide range of applications



\* Image shown may not reflect actual engine configuration.

### Engine data for general power specifications

Specifications			
Engine Model	<b>6BG1T</b>		
Engine Characteristics	4-Cycle, Water-Cooled, Vertical In-Line		
Valvetrain Configuration	Over Head Valve		
Type of Aspiration	Turbocharged		
Type of Injection	Direct		
No. of Cylinders	6		
Bore x Stroke	105 x 125 mm	4.13 x 4.92 in	
Displacement	6.494 liters	396 cu.in	
Overall Dimensions	Length	1201 mm	47.28 in
	Width	694 mm	27.32 in
	Height	949 mm	37.36 in
Dry Weight	466 kg	1027 lb	
Rated Output	121.6 / 2200 kW/min <sup>-1</sup>	163 / 2200 HP/rpm	
Max. Torque	553.6 / 1800 N·m/min <sup>-1</sup>	407 / 1800 lb·ft/rpm	

\* The data on this data sheet are for information purposes only and are not binding values.

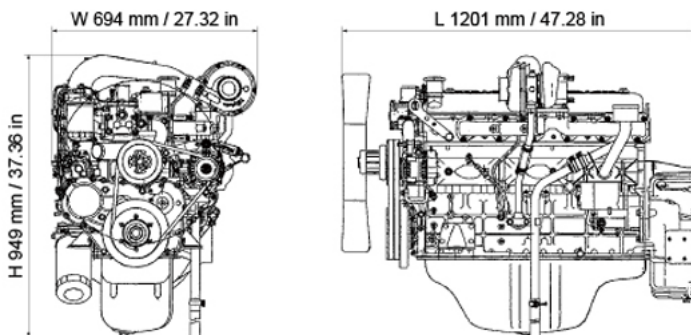

\* Appearance diagrams shown may not reflect actual engine configuration.  
\* Final dimensions are dependent on selected options.

### Performance Curve

#### Torque

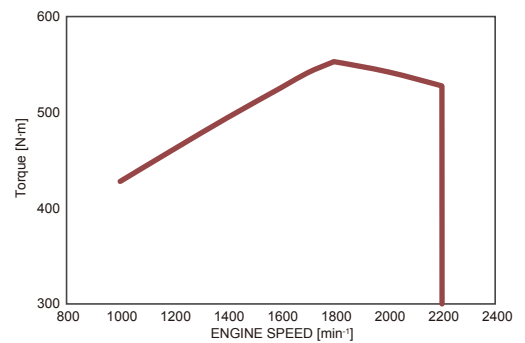

#### Power Output

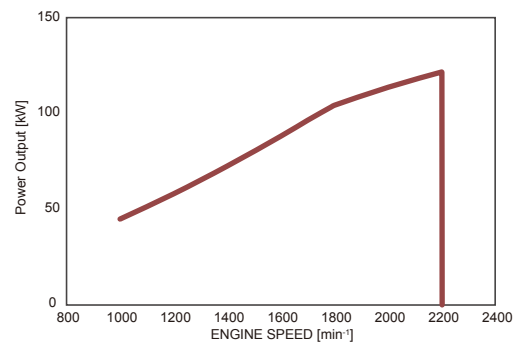

#### Fuel Consumption

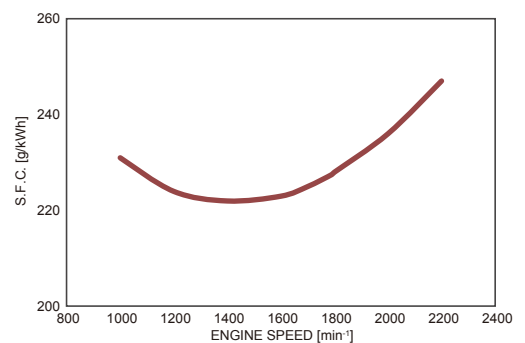

\* Performance curves shown are representative.