

3C Series Engine

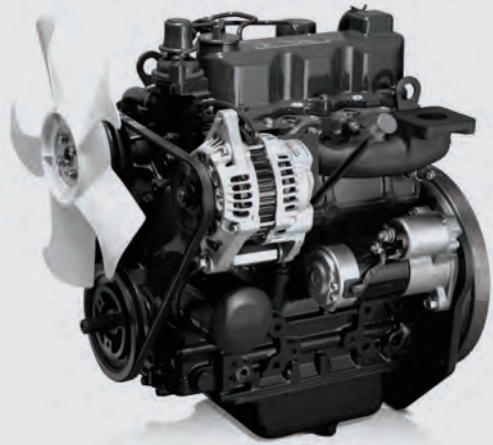

Model	3C100LW	3C100LF-22	3C100LF-24	
Type	Vertical Water-Cooled 4-Cycle Diesel Engine			
Emission compliance	Tier4	Tier4. NTE		
Aspiration	Naturally Aspirated			
Combustion type	Swirl Chamber			
Max power	kW(HP)/rpm	16.4(22)/2800	16.4(22)/3000	17.9(24)/3000
Peak torque	Nm(kgfm)/rpm	63.8(6.5)/1900	61(6.2)/2300	
Bare speed (low/high)	rpm	1050/3020	1350/3230	
Dimension (LxWxH)	mm	505x482x553	502x481x562	
Dry weight	kg(lb)	101(222)	100(220)	
Governor type	Mechanical	Mechanical+ECU		
Starter	12V-1.7kW			
Alternator	12V-50(70)Amp			
Flywheel / Housing	mm(in)	190(7-1/2) / SAE #5 & Rear plate		
Coolant Capacity	L	1.6		
Engine Oil capacity	L	3.8	3.2	

Dimension

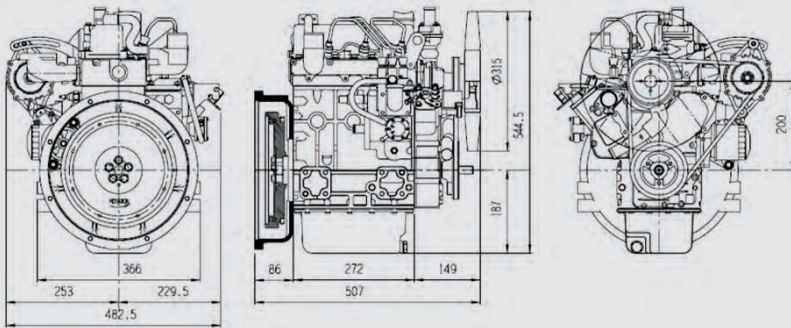

Performance

