

5" Air Cleaner fitted to 3CE1 110mm clearance is required to remove the end cap & element for renewal.

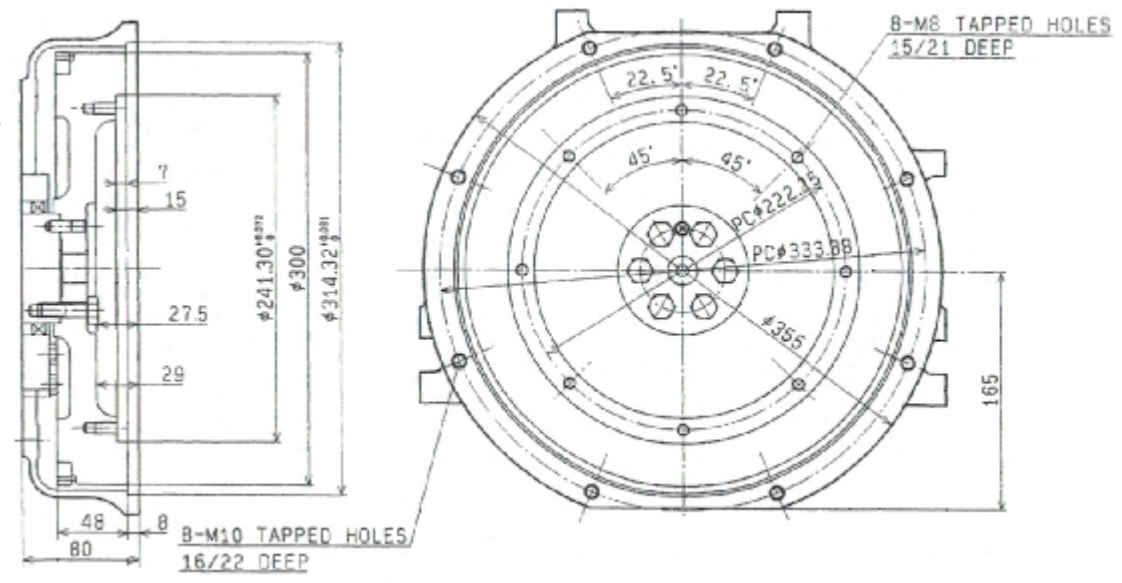

Semi SAE5/7.5" Housing & Flywheel

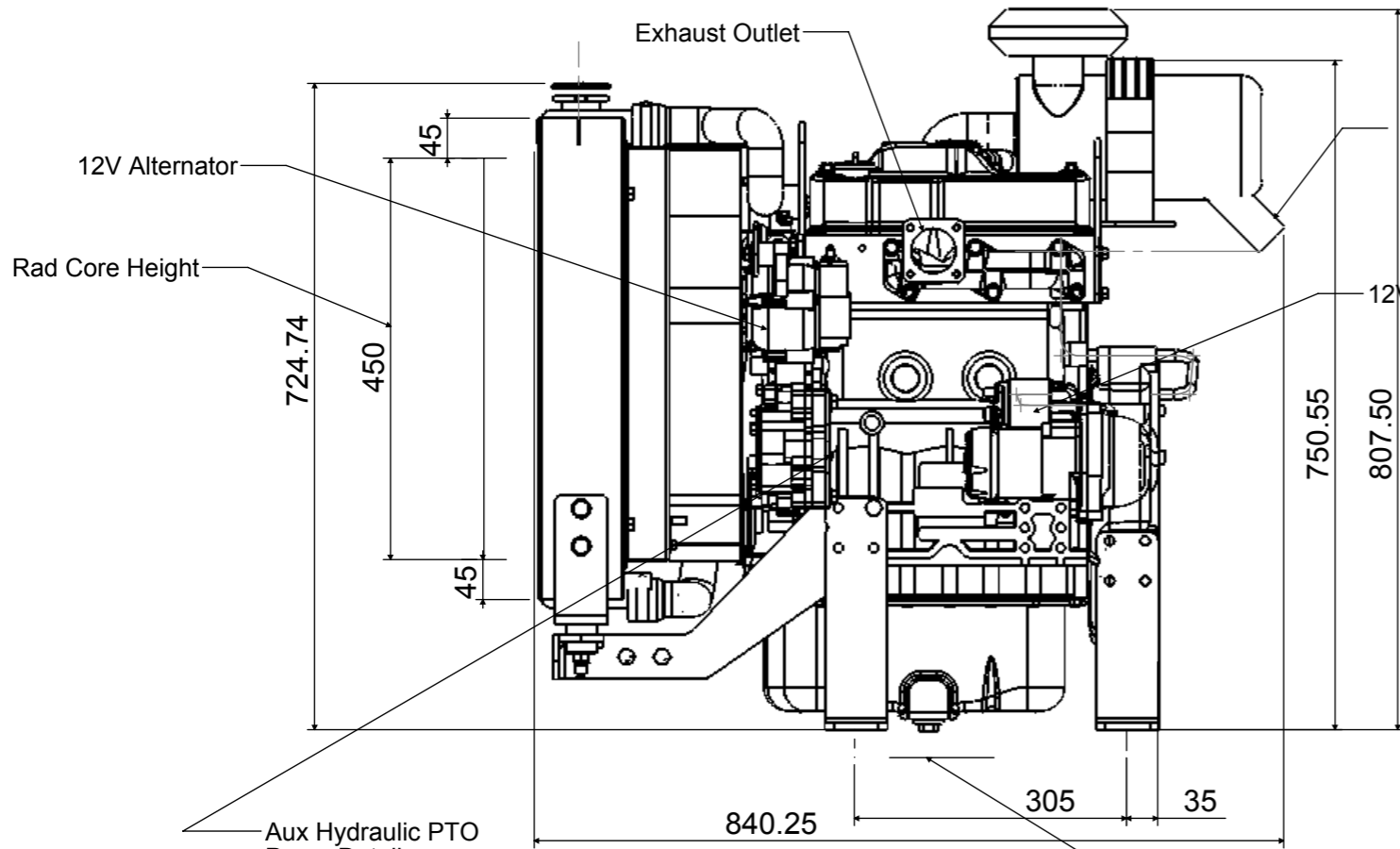

without inlet cap

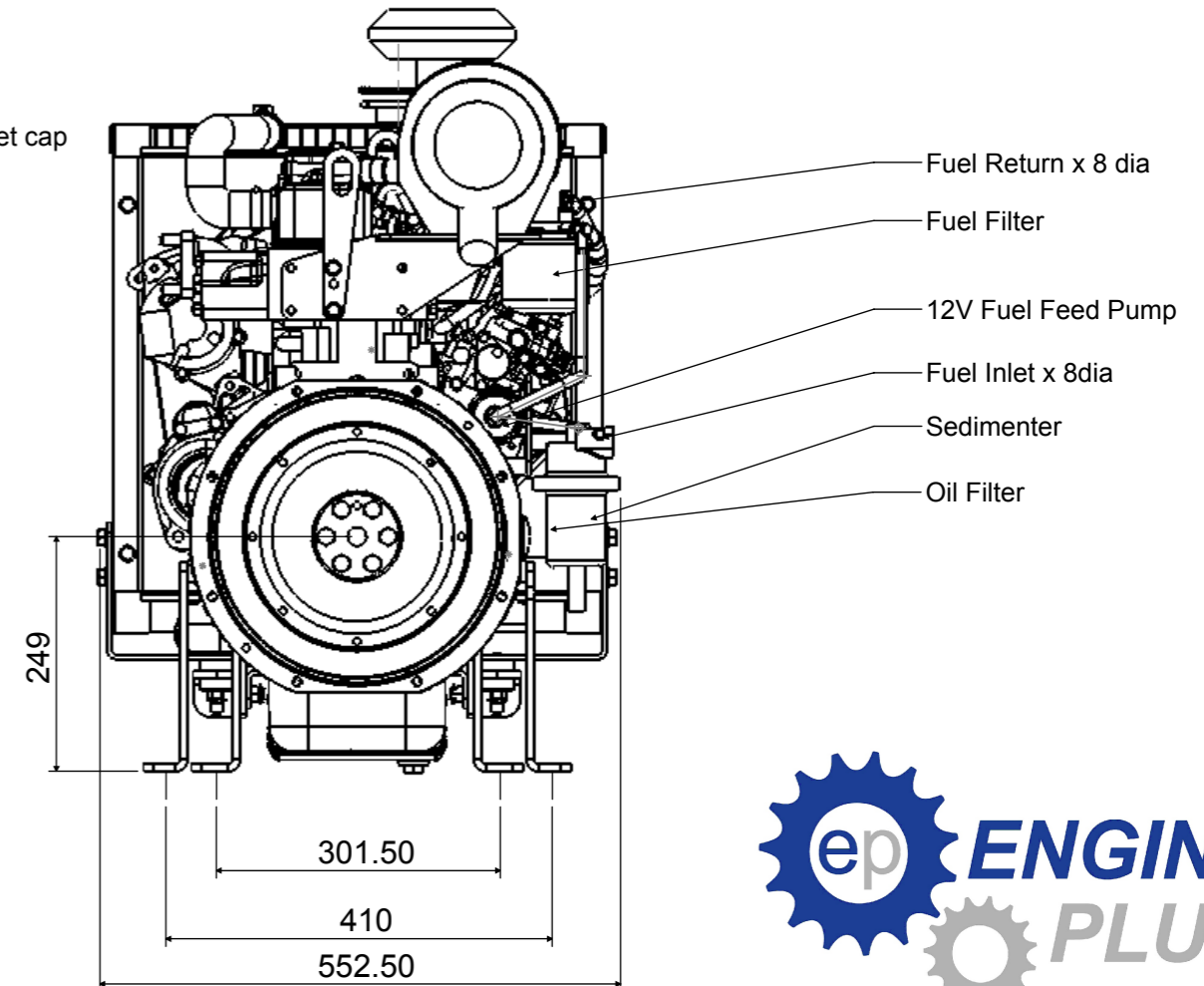

Aux Hydraulic PTO Pump Details...
SAE A Flange x 2 Bolt. Splined Shaft ~ 9 Tooth x 16/32 dp
Engine Speed : Pump Speed 1:0.913
Hydraulic Pump Rotation ~ Anticlockwise looking on pump shaft

20mm Clearance required for plug removal

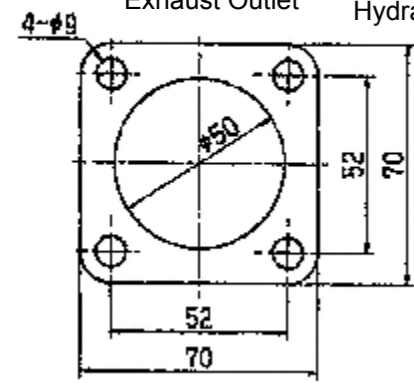

UNLESS OTHERWISE SPECIFIED:
ALL DIMENSIONS IN MM
LINEAR TOLERANCES: +/- 0.5MM
ANGULAR TOLERANCES: +/- 1.0°

This drawing is the copyright of ENGINES PLUS Ltd and may not be copied or distributed without their written permission

NAME	DATE	Drawing	REV: SEE TABLE
DRAWN Ryan Housam	30/06/2016	A	
CHK'D			
APPV'D			
MATERIAL: N/A			
FINISH: DO NOT SCALE DRAWING			
SHEET SIZE: A3		SCALE: 1:8 SHEET: 1 OF 1	

ENGINES PLUS Ltd

Drawing No: NIZ3CE1XNPP01GA

TITLE: Isuzu 3CE1BDZP5 Variable Speed Power Pack