

Oil & fuel filters are for remote mounting

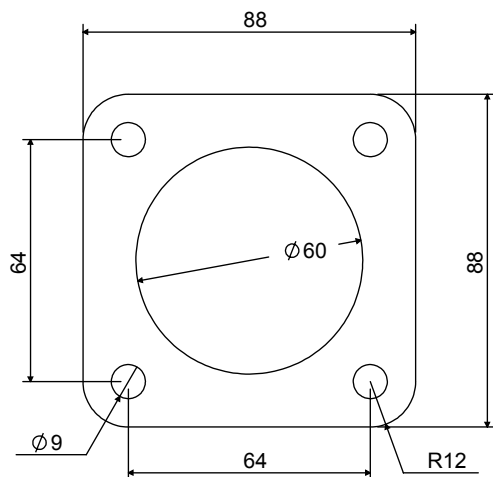
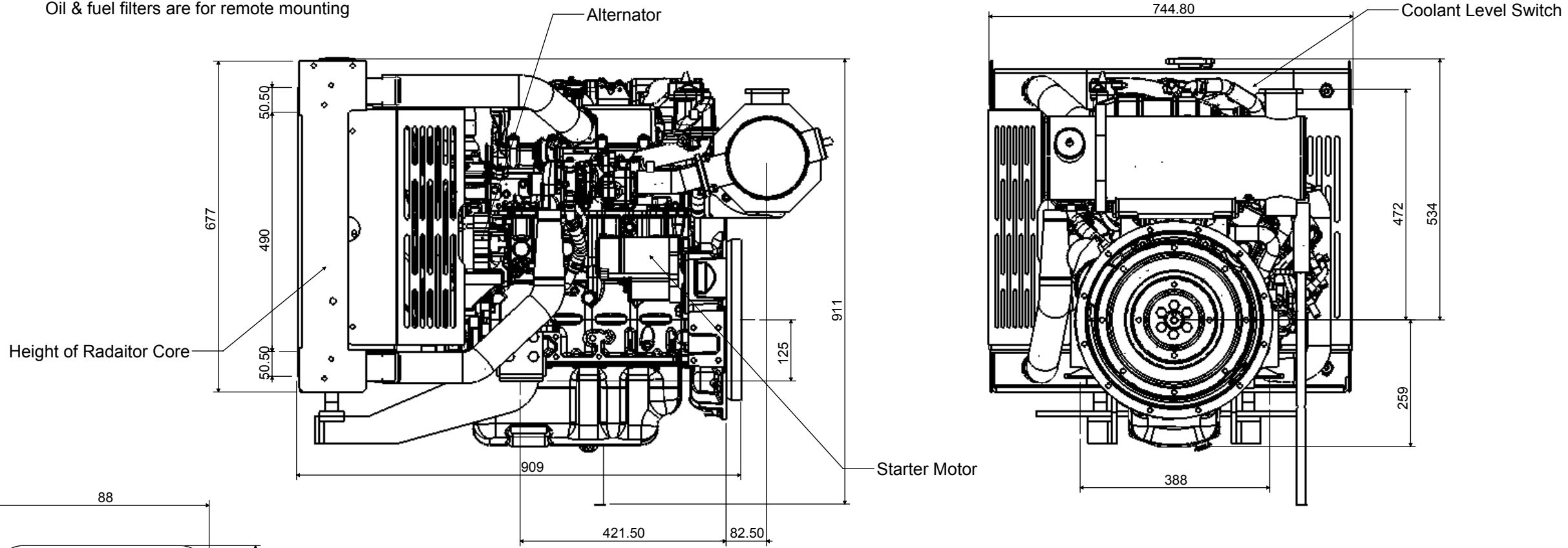

UNLESS OTHERWISE SPECIFIED:
ALL DIMENSIONS IN MM
LINEAR TOLERANCES: +/- 0.5MM
ANGULAR TOLERANCES: +/- 1.0°

This drawing is the copyright of ENGINES PLUS Ltd and may not be copied or distributed without their written permission

	NAME	DATE	Drawing	REV: SEE TABLE
DRAWN	Ryan Housam	23/01/2017	A	
CHK'D				
APPV'D				
MATERIAL: N/A				
FINISH: DO NOT SCALE DRAWING				
SHEET SIZE: A3		SCALE: 1:1 SHEET: 1 OF 1		

ENGINES PLUS Ltd

PART NO: NIZ4LE2XXPP01GA
TITLE: Isuzu NIZ4LE2XXPP01 Power Pack