

Tier 2

A 91.7 kW turbo-charged 4-cylinder engine

4BG1T

- Environmental performance that meets Tier 2 regulations
- Powerful 91.7 kW output
- Environmentally friendly and economical with low fuel consumption
- Lightweight and compact, with outstanding quiet performance
- Highly rated around the world for reliability and durability

► Suitable for a wide range of applications



* Image shown may not reflect actual engine configuration.

Engine data for general power specifications

Specifications			
Engine Model	4BG1T		
Engine Characteristics	4-Cycle, Water-Cooled, Vertical In-Line		
Valvetrain Configuration	Over Head Valve		
Type of Aspiration	Turbocharged		
Type of Injection	Direct		
No. of Cylinders	4		
Bore x Stroke	105 x 125 mm	4.13 x 4.92 in	
Displacement	4.329 liters	264 cu.in	
Overall Dimensions	Length	935 mm	36.81 in
	Width	666 mm	26.22 in
	Height	930 mm	36.61 in
Dry Weight	360 kg	793 lb	
Rated Output	91.7 / 2500 kW/min ⁻¹	123 / 2500 HP/rpm	
Max. Torque	387 / 2000 N·m/min ⁻¹	285 / 2000 lb·ft/rpm	

* The data on this data sheet are for information purposes only and are not binding values.

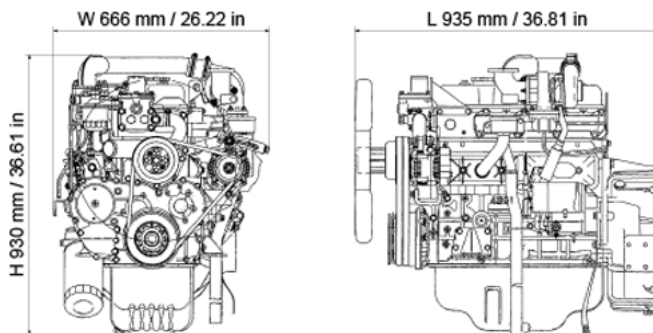

* Appearance diagrams shown may not reflect actual engine configuration.
* Final dimensions are dependent on selected options.

Performance Curve

Torque

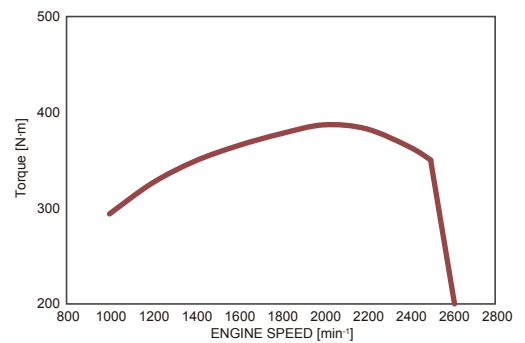

Power Output

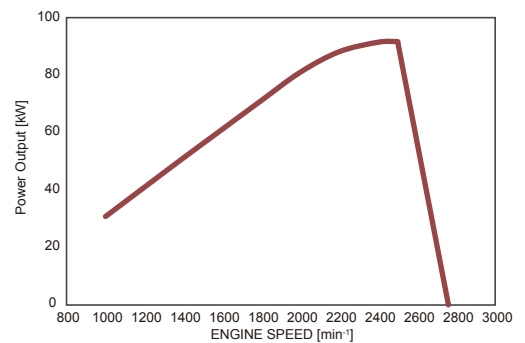

Fuel Consumption

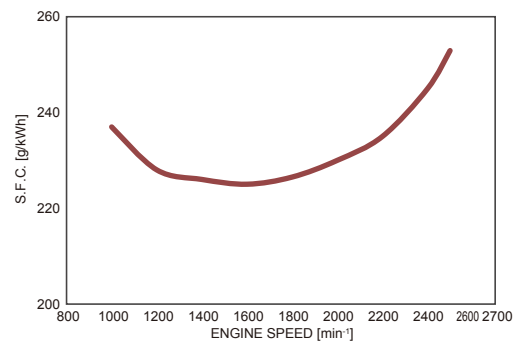

* Performance curves shown are representative.