

Tier 2

A lightweight, compact, direct-injection 4-cylinder engine

4JG1

- Environmental performance that meets Tier 2 regulations
- Powerful 46.3 kW output
- Environmentally friendly and economical with low fuel consumption
- Lightweight and compact, with outstanding quiet performance
- Highly rated around the world for reliability and durability

► Suitable for a wide range of applications

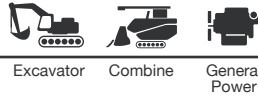

* Image shown may not reflect actual engine configuration.

Engine data for general power specifications

Specifications			
Engine Model	4JG1		
Engine Characteristics	4-Cycle, Water-Cooled, Vertical In-Line		
Valvetrain Configuration	Over Head Valve		
Type of Aspiration	Naturally Aspirated		
Type of Injection	Direct		
No. of Cylinders	4		
Bore x Stroke	95.4 x 107 mm	3.75 x 4.21 in	
Displacement	3.059 liters	186 cu.in	
Overall Dimensions	Length	812 mm	31.96 in
	Width	569 mm	22.40 in
	Height	779 mm	30.66 in
Dry Weight	244 kg	538 lb	
Rated Output	46.3 / 2600 kW/min ⁻¹	62.1 / 2600 HP/rpm	
Max. Torque	195 / 1800 N·m/min ⁻¹	143 / 1800 lb·ft/rpm	

* The data on this data sheet are for information purposes only and are not binding values.

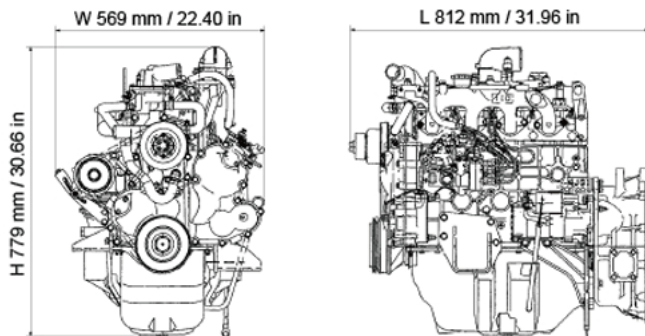

* Appearance diagrams shown may not reflect actual engine configuration.
* Final dimensions are dependent on selected options.

Performance Curve

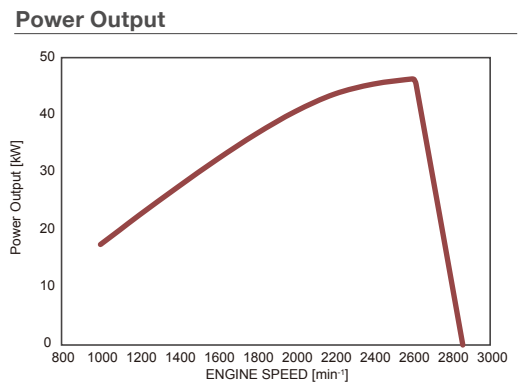
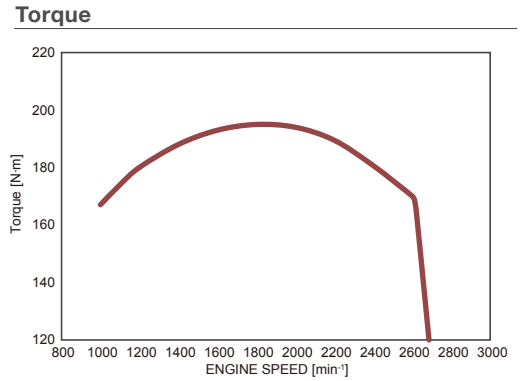

Fuel Consumption

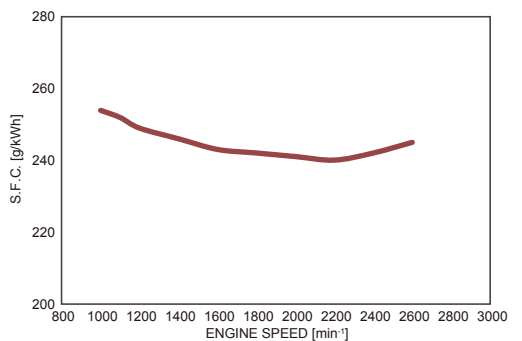

* Performance curves shown are representative.



Engines Plus Ltd

Unit F The Aquarius Centre, Edison Close, Waterwells Business Park, Quedgeley, Glos, GL2 2FN
Tel: + 44 1452 729707. E-mail: sales@enginesplus.co.uk