

Tier 2

A 62.5 kW turbo-charged 4-cylinder engine

4JG1T

- Environmental performance that meets Tier 2 regulations
- Powerful 62.5 kW output
- Environmentally friendly and economical with low fuel consumption
- Lightweight and compact, with outstanding quiet performance
- Highly rated around the world for reliability and durability

► Suitable for a wide range of applications

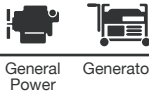

General Power Generator



* Image shown may not reflect actual engine configuration.

Engine data for general power specifications

Specifications			
Engine Model	4JG1T		
Engine Characteristics	4-Cycle, Water-Cooled, Vertical In-Line		
Valvetrain Configuration	Over Head Valve		
Type of Aspiration	Turbocharged		
Type of Injection	Direct		
No. of Cylinders	4		
Bore x Stroke	95.4 x 107 mm	3.75 x 4.21 in	
Displacement	3.059 liters	186 cu.in	
Overall Dimensions	Length	812 mm	31.96 in
	Width	596 mm	23.46 in
	Height	779 mm	30.66 in
Dry Weight	256 kg	564 lb	
Rated Output	62.5 / 2500 kW/min ⁻¹	83.8 / 2500 HP/rpm	
Max. Torque	262.8 / 1800 N·m/min ⁻¹	193 / 1800 lb·ft/rpm	

* The data on this data sheet are for information purposes only and are not binding values.

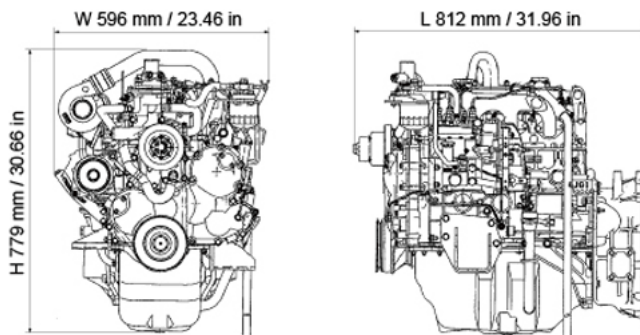

* Appearance diagrams shown may not reflect actual engine configuration.
* Final dimensions are dependent on selected options.

Performance Curve

Torque

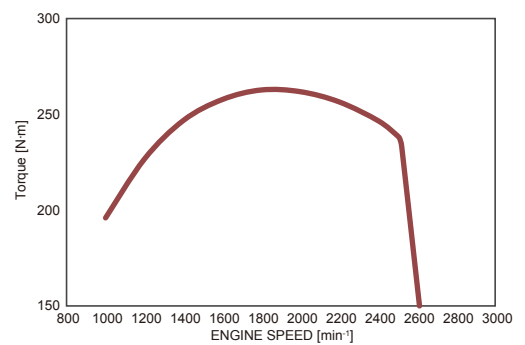

Power Output

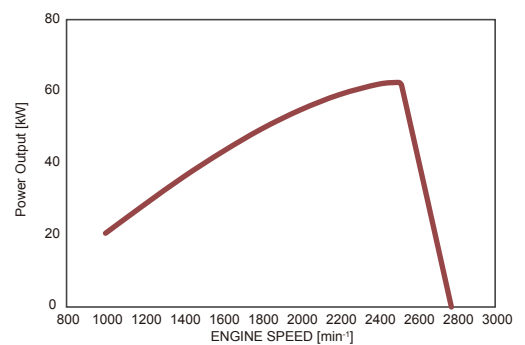

Fuel Consumption

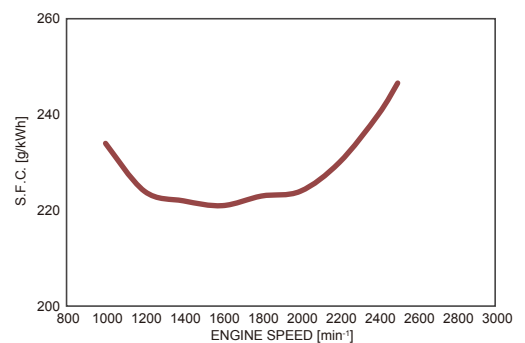

* Performance curves shown are representative.