

## Tier 2

A 6HK1X engine achieves power, environmental performance, and economy

# 6HK1X

- Environmental performance that meets Tier 2 regulations
- Powerful 183.9 kW output
- Environmentally friendly and economical with low fuel consumption
- Lightweight and compact, with outstanding quiet performance
- Highly rated around the world for reliability and durability

► Suitable for a wide range of applications



Excavator

General Power

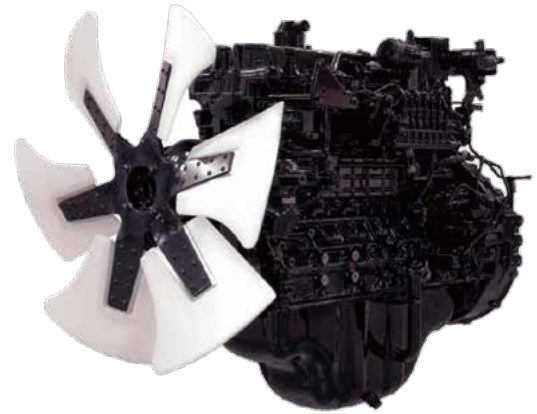

\* Image shown may not reflect actual engine configuration.

### Engine data for general power specifications

#### Specifications

Engine Model	<b>6HK1X</b>	
Engine Characteristics	4-Cycle, Water-Cooled, Vertical In-Line	
Valvetrain Configuration	Over Head Camshaft	
Type of Aspiration	Turbocharged and Charge Air Cooled	
Type of Injection	Direct	
No. of Cylinders	6	
Bore x Stroke	115 x 125 mm	4.52 x 4.92 in
Displacement	7.790 liters	475 cu.in
Overall Dimensions	Length	1332 mm / 52.44 in
	Width	996 mm / 39.21 in
	Height	1143 mm / 44.99 in
Dry Weight	650 kg	1433 lb
Rated Output	183.9 / 2000 kW/min <sup>-1</sup>	246 / 2000 HP/rpm
Max. Torque	872.8 / 1700 N·m/min <sup>-1</sup>	644 / 1700 lb·ft/rpm

\* The data on this data sheet are for information purposes only and are not binding values.

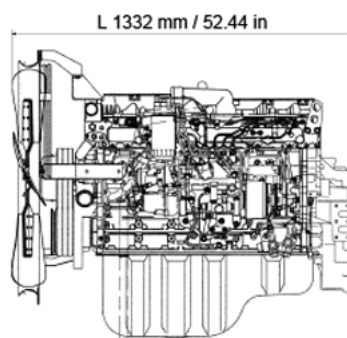
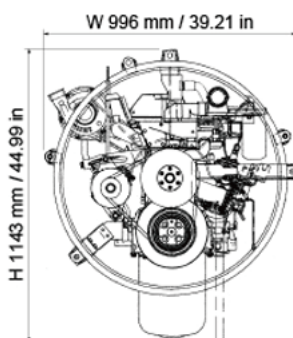

\* Appearance diagrams shown may not reflect actual engine configuration.

\* Final dimensions are dependent on selected options.

#### Performance Curve

##### Torque

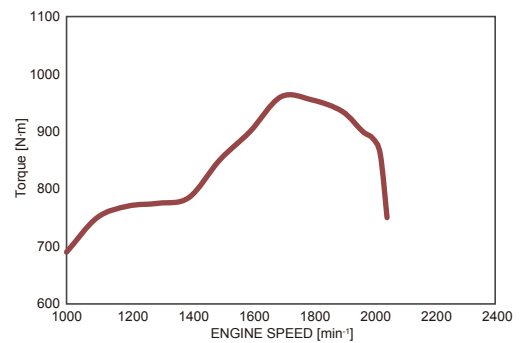

##### Power Output

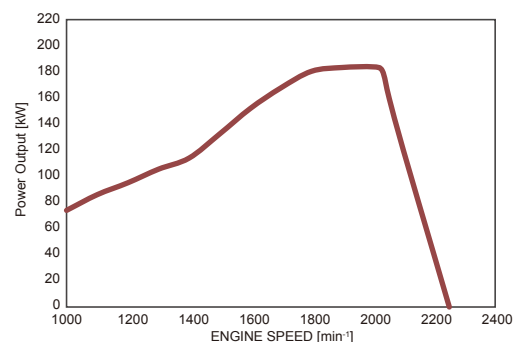

##### Fuel Consumption

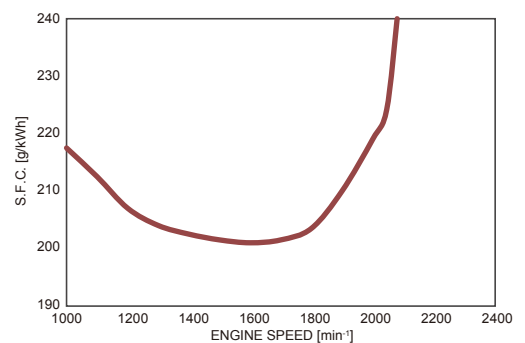

\* Performance curves shown are representative.