



daedong **daedong KIOTI**

3H183



Type	Rated RPM	Ratings (kW/HP)	
		Gross Engine Output	Net Engine Output
2620-2665	2600	26.1 / 35.0	25.3 / 34.4
3009-2665	2600	29.8 / 40.0	28.9 / 39.3

◎ GENERAL ENGINE DATA

▶ Emission Level	EEC : StageV, EPA : Tier4 Final, Korea : Tier4
▶ Engine Type	3-Cylinder, 4-Cycle, In-line, Diesel, Water cooled, N/A
▶ Bore x Stroke	Ø87×102.4 mm
▶ Displacement	1.826 liters
▶ Compression Ratio	18.3±0.2 : 1
▶ Combustor Type	Common Rail Direct Injection(CRDI)
▶ Rotation	Counter clockwise viewed from Flywheel
▶ Dimension (L x W x H)	652.7 x 548.2 x 897 mm
▶ Dry Weight	200kg (with Fan and plate type)
▶ Rated Power [kW(HP)/rpm]	2620-2665 : 26.1(35.0) / 2600 3009-2665 : 29.8(40.0) / 2600
▶ High Idle Rpm	2750±50
▶ Low Idle Rpm	1030±50
▶ Max. Torque [N·m(kgf·m)/rpm]	2620-2665 : 115(11.7) / 1800±100 3009-2665 : 118(12) / 1800±100
▶ Aspiration	N/A
▶ Governor Type	Electric Control (ECU)
▶ Injection timing	Auto Control
▶ Alternator Capacity	12V-75A
▶ Firing order	1-2-3
▶ Flywheel housing	SAE No.4
▶ Flywheel	Clutch No.7-1/2
▶ After Treatment	CCRT(DOC+DPF)



daedong

daedong
KIOTI

◆ ENGINE DIMENSION

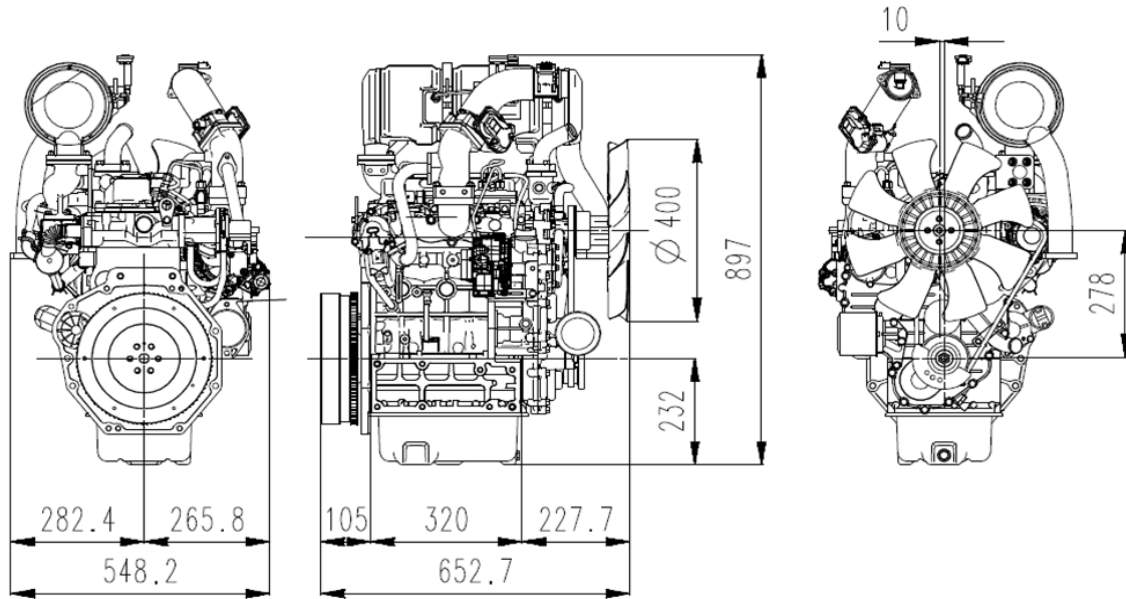

Designation	Length(L)	Width(W)	Height(H)	Dry weight
Value	652.7	548.2	897	200

◆ Performance Curve

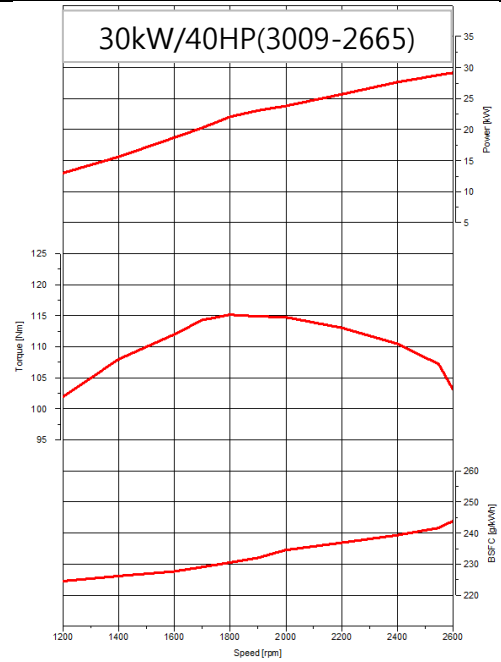
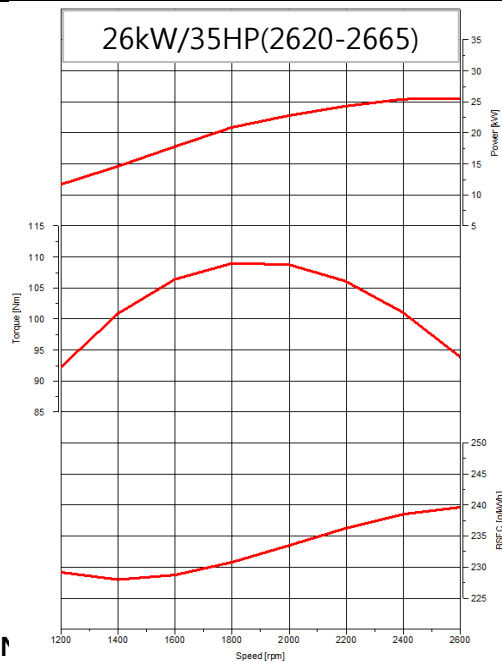

◆ COI

in. = mm x 0.0394

PS = kW x 1.3596

psi = kg/cm² x 14.2233

in³ = lit. x 61.02

hp = PS x 0.98635

lb = kg x 2.20462

kW = Kcal/sec x 0.239

lb/ft = N.m x 0.737

U.S. gal = lit. x 0.264

kW = 0.2388 kcal/s

lb/PS.h = g/kW.h x 0.00162

cfm = m³ /min x 35.336

Mpa = Pa x 1000 = bar x 10